

# \*TB 9-6625-1996-24

DEPARTMENT OF THE ARMY TECHNICAL BULLETIN

## CALIBRATION PROCEDURE FOR FREQUENCY COUNTER HEWLETT-PACKARD MODELS 5345A, 5345-H25, 5345-C15, 5345A/E28, 5345A011 AND 5345AOPT012

Headquarters, Department of the Army, Washington, DC  
3 October 2008

*Distribution Statement A: Approved for public release; distribution is unlimited.*

### REPORTING OF ERRORS AND RECOMMENDING IMPROVEMENTS

You can improve this manual. If you find any mistakes or if you know of a way to improve these procedures, please let us know. Mail your letter or DA Form 2028 (Recommended Changes to Publications and Blank Forms) directly to: Commander, U.S. Army Aviation and Missile Command, ATTN: AMSAM-MMC-MA-NP, Redstone Arsenal, AL 35898-5000. A reply will be furnished to you. You may also send in your comments electronically to our E-mail address: [2028@redstone.army.mil](mailto:2028@redstone.army.mil) or by fax 256-842-6546/DSN 788-6546. For the World Wide Web use: <https://amcom2028.redstone.army.mil>. Instructions for sending an electronic 2028 can be found at the back of this manual.

SECTION		Paragraph	Page
I.	IDENTIFICATION AND DESCRIPTION		
	Test instrument identification .....	1	2
	Forms, records, and reports.....	2	2
	Calibration description.....	3	2
II.	EQUIPMENT REQUIREMENTS		
	Equipment required.....	4	3
	Accessories required .....	5	3
III.	CALIBRATION PROCESS		
	Preliminary instructions .....	6	4
	Equipment setup.....	7	4
	Time base stability.....	8	5
	Sensitivity.....	9	6
	A12 Interface I/O.....	10	8
	Power supply .....	11	9
	Final procedure .....	12	11

\*This bulletin supersedes TB 9-6625-1996-35, dated 25 June 2001, including all changes.

**SECTION I  
IDENTIFICATION AND DESCRIPTION**

**1. Test Instrument Identification.** This bulletin provides instructions for the calibration of Frequency Counter, Hewlett-Packard, Models 5345A, 5345-H25, 5345-C15, 5345A/E28, 5345A011 and 5345AOPT012. The manufacturers' manuals were used as the prime data sources in compiling these instructions. The equipment being calibrated will be referred to as the TI (test instrument) throughout this bulletin.

**a. Model Variations.** Differences among models are listed within the text.

**b. Time and Technique.** The time required for this calibration is approximately 2 hours, using the dc and low frequency technique.

**2. Forms, Records, and Reports.**

**a.** Forms, records and reports required for calibration personnel at all levels are prescribed by TB 750-25.

**b.** Adjustments to be reported are designated (R) at the end of the sentence in which they appear. When adjustments are in tables, the (R) follows the designated adjustment. Report only those adjustments made and designated with (R).

**3. Calibration Description.** TI parameters and performance applications which pertain to this calibration are in table 1.

Table 1. Calibration Description

Test instrument parameters	Performance specifications
Time base:	Frequency: 10 MHz Aging rate (after 24 hour warm-up): $< 5 \times 10^{-10}$ per day Line voltage variation (for 10% variation): $< 1 \times 10^{-10}$ 15 minutes after change
Channel A and B sensitivity:	Separate inputs: 25 mV rms: dc to 500 MHz (dc coupled)  Common inputs: 50 mV rms: dc to 400 MHz (dc coupled)
A12 interface I/O	Range: -2 to +2 V dc Accuracy: $\pm 0.0005$ V dc

## SECTION II EQUIPMENT REQUIREMENTS

**4. Equipment Required.** Table 2 identifies the specific equipment to be used in this calibration procedure. This equipment is issued with Secondary Transfer Calibration Standards Set AN/GSM-286, AN/GSM-287 or AN/GSM-705. Alternate items may be used by the calibrating activity. The items selected must be verified to perform satisfactorily prior to use and must bear evidence of current calibration. The equipment must meet or exceed the minimum use specifications listed in table 2. The accuracies listed in table 2 provide a four-to-one ratio between the standard and TI.

**5. Accessories Required.** The accessories required for this calibration are common usage accessories, issued as indicated in paragraph 4 above, and are not listed in this calibration procedure. The following peculiar accessories are also required for this calibration: Adapter, SMC jack to BNC plug, Hewlett-Packard Model 1250-0831; Extender Boards, 10-terminal circuit board extenders (05345-60201 and 05345-60202); and Extender Cable, Hewlett-Packard Model 05345-60205.

Table 2. Minimum Specifications of Equipment Required

Common name	Minimum use specifications	Manufacturer and model (part number)
AUTOTRANSFORMER	Range: 105 to 125 V ac Accuracy: $\pm 1\%$	Ridge, Model 9020A (9020A)
FUNCTION GENERATOR	Range: 10 Hz to 30 MHz Amplitude: 0 to 40 mV rms Accuracy: $\pm 3\%$ ( $\pm 1.5$ dB)	(SG-1288/G)
FREQUENCY DIFFERENCE METER	Range: 10 MHz Resolution: 1 part in $10^{-10}$ per day	Tracor, Model 527E (527E)
MULTIMETER	Range: -2 to +2 Vdc Accuracy: $\pm 0.000125\%$ Range: 0 to $\pm 15$ V dc Accuracy: $\pm 0.03\%$	Hewlett-Packard, Model 3458A (3458A)
OSCILLOSCOPE	Bandwidth: 100 MHz Sensitivity: 50 mV/div Sweep rate: 10 ns/div Accuracy: $\pm 3\%$	Agilent, OS-303/G (OS-303/G)
SIGNAL GENERATOR	Range: 30 to 500 MHz Amplitude: 0 to 40 mV rms Accuracy: $\pm 3\%$ ( $\pm 1.5$ dB)	Aeroflex, Model 2023B (2023B) or (SG-1207/U)
TIME/FREQUENCY WORKSTATION	Frequency: 10 MHz Accuracy: 1.25 parts in $10^{-10}$ per day	Datum, Model ET6000-75 (13589305)

### SECTION III CALIBRATION PROCESS

#### 6. Preliminary Instructions

a. The instruction outlined in paragraphs 6 and 7 are preparatory to the calibration process. Personnel should become familiar with the entire bulletin before beginning the calibration.

b. Items of equipment used in this procedure are referenced within the text by common name as listed in table 2.

c. Unless otherwise specified, verify the result of each test and, whenever the test requirement is not met, take corrective action before continuing with the calibration. Adjustments required to calibrate the TI are included in this procedure. Additional maintenance information is contained in the manufacturer's manual for this TI.

d. Unless otherwise specified, all controls and control settings refer to the TI.

#### 7. Equipment Setup

##### WARNING

HIGH VOLTAGE is used or exposed during the performance of this calibration. DEATH ON CONTACT may result if personnel fail to observe safety precautions. REDUCE OUTPUT(S) to minimum after each step within the performance check where applicable.

a. Remove protective cover from TI only when necessary to make adjustments. Replace cover after completing the adjustments.

b. Connect TI rear panel **DIGITAL BUS 1.0 LOAD** to controller GPIB0 (OPT 12 only).

c. Connect TI to autotransformer, connect autotransformer to a 115 V ac source and adjust for 115 V ac output.

d. Set **POWER** switch to **ON** and allow at least 1 hour for stabilization. If TI has been disconnected from line power for more than 24 hours, allow at least 24 hours for warm-up before beginning calibration.

e. Set TI rear panel **INT STD/EXT STD** switch to **INT STD** and **INTERNAL/EXT ARM/EXT GATE** switch to **INTERNAL** (OPT 12 only).

f. Position controls as listed in (1) through (10) below:

- (1) **FUNCTION** switch to **FREQ A**.
- (2) **GATE TIME** switch to **100 ms**.
- (3) **DISPLAY POSITION** switch to **AUTO**.
- (4) **SAMPLE RATE** control fully ccw.
- (5) **CHANNEL A** and **B LEVEL** controls to **PRESET**.

- (6) CHANNEL A and B SLOPE switches to + (positive).
- (7) CHANNEL A and B input impedance switches to  $50 \Omega$ .
- (8) CHANNEL A and B ATTEN switches to X1.
- (9) CHANNEL A and B AC-DC switches to DC.
- (10) CHECK-COM A-SEP switch to SEP.

## 8. Time Base Stability

### a. Performance Check

- (1) Connect a time/frequency workstation 1 MHz output to frequency difference meter REF INPUT.
- (2) Connect TI FREQ STD OUTPUT 10 MHz (rear panel) to frequency difference meter SIG INPUT.
- (3) Adjust A18 FREQ ADJ (fig. 1) for minimum difference indication on frequency difference meter.

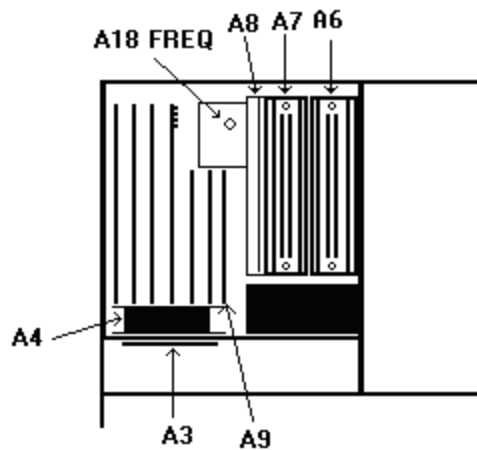

Figure 1. Test instrument - top view.

- (4) Allow at least 24 hours for stabilization. Frequency difference meter indication will remain within 5 parts in  $10^{-10}$ .
- (5) Adjust autotransformer output to 105 V and allow 15 minutes for stabilization. Verify that TI oscillator drift is less than 1 part in  $10^{-10}$ .
- (6) Adjust autotransformer output to 125 V and allow 15 minutes for stabilization. Verify that TI oscillator drift is less than 1 part in  $10^{-10}$ .
- (7) Adjust autotransformer output to 115 V.

### b. Adjustments. No further adjustments can be made.

9. Sensitivity

a. Performance Check

(1) Set function generator as listed in (a) through (d) below:

- (a) **Function Outputs** to **50Ω**.
- (b) **Function** to sine wave.
- (c) **Frequency** to 10 Hz.
- (d) **Amplitude** to 0.001 VPP.

(2) Position TI controls as listed in (a) through (f) below:

- (a) **CHANNEL A LEVEL** control to **PRESET**.
- (b) **CHANNEL A SLOPE** switch to **+**.
- (c) **CHANNEL A 50Ω/1MΩ** switch to **50Ω**.
- (d) **CHANNEL A ATTEN X1/X10** switch to **X1**.
- (e) **CHANNEL A AC/DC** switch to **DC**.
- (f) **CHECK/COM A/SEP** switch to **SEP**.

(3) Connect TI **CHANNEL A** input to function generator **Function Output Unbalanced**.

(4) Press the function generator **Enter** key to enable the knob, and slowly rotate the function generator knob cw until TI display **GATE** light flashes and indication is stable at approximately 10 Hz.

(5) Verify that the function generator indicates within limits specified in table 3. If not perform **b** below.

(6) Repeat technique of (1) through (5) above for remaining settings listed in table 3.

Table 3. Sensitivity

Test instrument input	CHECK-COM A-SEP switch setting	Function generator/signal generator frequency setting	Function generator/signal generator indications (≤)
CHANNEL A	SEP	10 Hz	0.071 VPP
CHANNEL A	SEP	10 kHz	0.071 VPP
CHANNEL A	SEP	100 kHz	0.071 VPP
CHANNEL A	SEP	1 MHz	0.071 VPP
CHANNEL A <sup>1</sup>	SEP	10 MHz	0.025 VRMS
CHANNEL A	SEP	100 MHz	0.025 VRMS
CHANNEL A	SEP	500 MHz	0.025 VRMS
CHANNEL A <sup>2</sup>	COM A	10 Hz	0.141 VPP
CHANNEL A	COM A	10 kHz	0.141 VPP
CHANNEL A	COM A	100 kHz	0.141 VPP
CHANNEL A	COM A	1 MHz	0.141 VPP
CHANNEL A <sup>1</sup>	COM A	10 MHz	0.050 VRMS
CHANNEL A	COM A	100 MHz	0.050 VRMS
CHANNEL A	COM A	400 MHz	0.050 VRMS

<sup>1</sup>Substitute the signal generator for the function generator.

<sup>2</sup>Substitute the function generator for the signal generator.

## b. Adjustments

- (1) Substitute signal generator for function generator.
- (2) Connect signal generator **RF OUTPUT** connector to **TI CHANNEL A** input.
- (3) Connect signal generator external reference input connector (rear panel) to **TI FREQ STD OUTPUT 10 MHz** connector (rear panel).
- (4) Extend front panel display assembly using extender cable 05345-60205. Disconnect **CHAN A P1** cable from **A9 J1 CHA** (**CHAN B P2** cable to **A9 J2 CH B** for **CHANNEL B**) and connect **A9 J1 CH A** (**A9 J2 CH B** for **CHANNEL B**) to oscilloscope **Vertical 1** input.
- (5) Position **TI CHANNEL A** and **CHANNEL B** controls as listed in (a) through (f) below:
  - (a) **LEVEL** control to **PRESET**.
  - (b) **SLOPE** switch to **+**.
  - (c) **IMPEDANCE** switch to **50Ω**.
  - (d) **ATTEN** switch to **X1**.
  - (e) **COUPLING** switch to **DC**.
  - (f) **CHECK-COM A-SEP** switch to **SEP**.
- (6) Set signal generator frequency to 100 MHz and amplitude to 25 mV.
- (7) Position oscilloscope controls as listed in (a) through (f) below:
  - (a) **Vertical 1** scale to **200 mV**.
  - (b) Sweep speed to **20 ns**.
  - (c) Press **Horizontal Delayed** (lit) and set sweep speed to **10 ns**.
  - (d) **Trigger Sweep** to **Auto**.
  - (e) **Trigger Source** to **1**.
  - (f) **Trigger Coupling** to **DC**.
- (8) Adjust **A3R41** (fig. 2) and **A3R3** (fig. 2) for **CHANNEL B** for a symmetrical waveform displayed on oscilloscope (R).

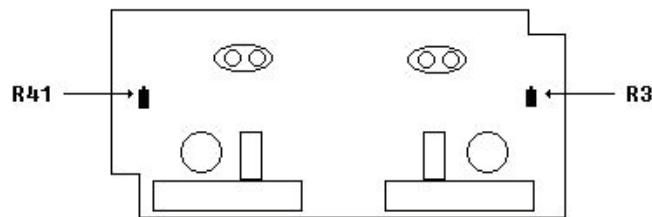

Figure 2. A3 input attenuator (component side).

- (9) While alternately setting **CHANNEL A** and **CHANNEL B SLOPE** switches to **(+)** and **(-)**, observe that waveform maintains its symmetrical form.
- (10) Repeat (8) and (9) above as required to compensate for interaction.

(11) Disconnect oscilloscope and signal generator from TI, reinstall TI from panel, and reconnect CHAN A P1 cable to A9 J1 CH A and CHAN B P2 cable to A9 J2 CH B.

(12) Replace TI covers.

**10. A12 Interface I/O**

**a. Performance Check**

**NOTE**

This option can only be calibrated in an automated mode. The TI must be connected to a controller with a properly configured GPIB IEEE interface card.

**NOTE**

If you are running this section with any controller and or software other than the fielded controller and the ICE environment, you will have to write the required mnemonics and take reading as per the software that you are using.

- (1) Connect TI and multimeter IEEE connectors to the controller GPIB0.
- (2) Assure TI address is set to 2 and multimeter address is set to 12.
- (3) Adjust TI **CHANNEL A** and **CHANNEL B LEVEL** controls to **PRESET**.
- (4) Remove screws holding TI top cover. Do not remove top cover until instructed.
- (5) Press the **RESET** key on the multimeter.
- (6) Output the following mnemonic string to the TI: I2B500A500I1.
- (7) Connect multimeter Input **HI** and **LO** to TI rear panel **CHAN A TRIG LEVEL**.
- (8) Output the following mnemonic string to the TI: B500A000I1.
- (9) Retrieve the reading from the multimeter. If the reading is not within limits listed in table 4, perform the listed adjustment.
- (10) Repeat technique of (7) through (9) above for remaining table 4 entries.

Table 4. A12 interface I/O

Output mnemonic	Connect multimeter to test instrument rear panel connector	Multimeter indication		
		Min	Max	Perform adjust listed below
B500A000I1	CHAN A TRIG LEVEL	-2.0005	-1.9995	<b>b1</b>
A:00I1	CHAN A TRIG LEVEL	1.9995	2.0005	<b>b2</b>
B000I1	CHAN B TRIG LEVEL	-2.0005	-1.9995	<b>b3</b>
B:00I1	CHAN B TRIG LEVEL	1.9995	2.0005	<b>b4</b>



## b. Adjustments

### NOTE

Remove top cover to make adjustments, then replace top cover before repeating (a) above.

- (1) Adjust A12 pot A (R69) (fig. 3) for a  $-2.0000 \pm 0.0005$  V dc multimeter indication (R).
- (2) Adjust A12 pot B (R74) (fig. 3) for a  $2.0000 \pm 0.0005$  V dc multimeter indication (R).
- (3) Adjust A12 pot D (R86) (fig. 3) for a  $-2.0000 \pm 0.0005$  V dc multimeter indication (R).
- (4) Adjust A12 pot C (R82) (fig. 3) for a  $+2.0000 \pm 0.0005$  V dc multimeter indication (R).

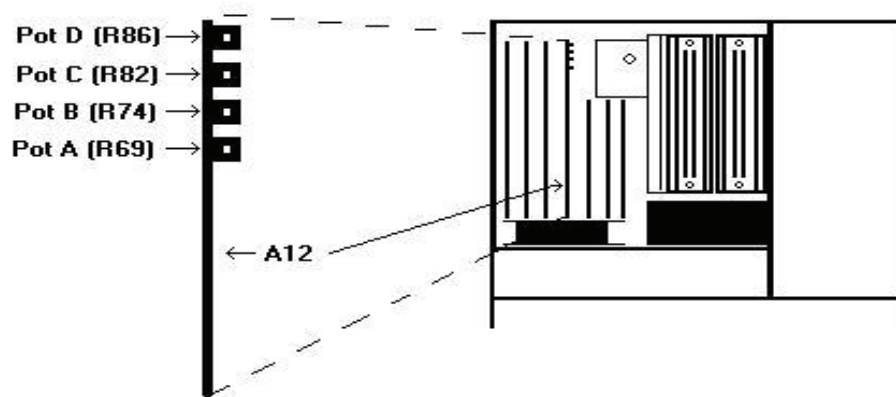

Figure 3. I/O adjustment location.

## 11. Power Supply

### NOTE

Do not perform power supply check if all other parameters are within tolerance.

### a. Performance Check

- (1) Mount circuit board A6 (fig. 1) on extender boards.
- (2) Connect multimeter between A6TP6 and + 5 V RET (fig. 4). If multimeter does not indicate between 4.98 and 5.02 V dc, perform **b** (1) below.
- (3) Connect multimeter between A6TP3 and - 5.2 V RET (fig. 4). If multimeter does not indicate between -5.18 and -5.22 V, perform **b** (2) below.
- (4) Replace circuit board A6 in TI and mount circuit board A7 (fig. 1) on extender boards.

(5) Connect multimeter between A7TP1 (A7TP2; serial prefix 1428A and prior) and + 15 RET (fig. 4). If multimeter does not indicate between 14.98 and 15.02 V, perform **b** (3) below.

(6) Connect multimeter between A7TP3 (A7TP7; serial prefix 1428A and prior) and -15 V RET (fig. 4). If multimeter does not indicate between -14.98 and -15.02 V, perform **b**(4) below.

**b. Adjustments**

(1) Adjust R19 (fig. 4) for 5.00 V indication on multimeter (R).

(2) Adjust R29 (fig. 4) for 5.20 V indication on multimeter (R).

(3) Adjust R16 (fig. 54) (R18 (fig. 4); serial prefix 1428A and prior) for +15.00 V indication on multimeter (R).

(4) Adjust R17 (fig. 4) (R24 (fig. 4); serial prefix 1428A and prior) for -15.00 V indication on multimeter (R).

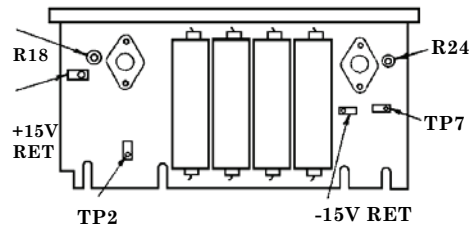

A7 CIRCUIT BOARD S/N 1428A

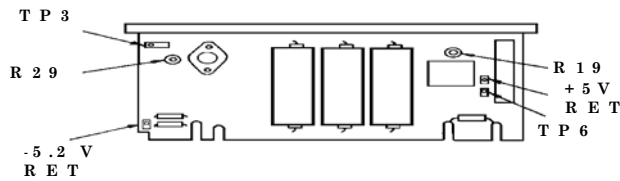

A6 CIRCUIT BOARD

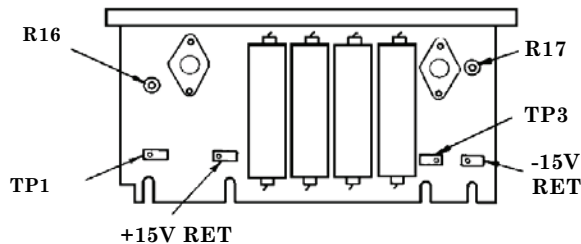

A7 CIRCUIT BOARD S/N 1808

Figure 4. Power supply circuit boards.

**12. Final Procedure**

- a. Deenergize and disconnect all equipment.
- b. Annotate and affix DA label/form in accordance with TB 750-25.



By Order of the Secretary of the Army:

Official  
  
JOYCE E. MORROW  
*Administrative Assistant to the  
Secretary of the Army*

0719032

GEORGE W. CASEY, JR.  
*General, United States Army  
Chief of Staff*

Distribution:

To be distributed in accordance with the initial distribution number (IDN) 342172, requirements for calibration procedure TB 9-6625-1996-24.



### Instructions for Submitting an Electronic 2028

The following format must be used if submitting an electronic 2028. The subject line must be exactly the same and all fields must be included; however, only the following fields are mandatory: 1, 3, 4, 5, 6, 7, 8, 9, 10, 13, 15, 16, 17, and 27.

From: "Whomever" [whomever@redstone.army.mil](mailto:whomever@redstone.army.mil)  
To: <2028@redstone.army.mil

Subject: DA Form 2028

1. **From:** Joe Smith
2. **Unit:** home
3. **Address:** 4300 Park
4. **City:** Hometown
5. **St:** MO
6. **Zip:** 77777
7. **Date Sent:** 19-OCT -93
8. **Pub no:** 55-2840-229-23
9. **Pub Title:** TM
10. **Publication Date:** 04-JUL-85
11. **Change Number:** 7
12. **Submitter Rank:** MSG
13. **Submitter FName:** Joe
14. **Submitter MName:** T
15. **Submitter LName:** Smith
16. **Submitter Phone:** 123-123-1234
17. **Problem:** 1
18. **Page:** 2
19. **Paragraph:** 3
20. **Line:** 4
21. **NSN:** 5
22. **Reference:** 6
23. **Figure:** 7
24. **Table:** 8
25. **Item:** 9
26. **Total:** 123
27. **Text**

This is the text for the problem below line 27.







